

定格電流 RATED CURRENT	△ *1)品番 *1)PART No.	△ *2)包装品番 *2)PACKAGING PART No.
500A	△ 29750010	△ 29750011
600A	△ 29700010	△ 29700011
700A	△ 29710010	△ 29710011
800A	△ 29720010	△ 29720011
900A	△ 29730010	△ 29730011
1000A	△ 29740010	△ 29740011

- △ *1)品番は単一のヒューズを示す。
 △ *2)包装品番は、包装仕様で定義されている単一の包装(段ボール箱)の品番を示す。
- △ *1)PART NO. INDICATES A SINGLE FUSE.
 △ *2)PACKAGING PART NO. INDICATES THE PART NO. OF A SINGLE PACKAGING UNIT (CARDBOARD BOX) AS DEFINED ON THE UNDER PACKAGING SPECIFICATION.

NO.	DATE	REVISION RECORDS	REVISED	REVISION NO.
△	07/NOV/2017	ADD PARTS NUMBER	K.SAKAI	-
△	16/JUL/2019	ADD PACKAGING SPECIFICATION.	H.NISHIMURA	-
△	03/JUL/2020	CHANGE BREAKING CAPACITY AND PART NO.	S.KATAOKA	-

仕様

- 定格電圧 : 500VDC
- 定格遮断容量 : 30000A △
- 使用温度範囲 : -40℃~100℃
- 保管温度範囲 : -40℃~85℃
- ヒューズ性能 : 太平洋精工規格PES-A52-079に準ずる。
- ヒューズの固定方法 : M10ボルト2本で固定。
- PES-02-04の環境負荷物質の使用禁止・制限規定を遵守する事。

SPECIFICATIONS

- RATED VOLTAGE : 500VDC
- BREAKING CAPACITY : 30000A △
- OPERATING TEMPERATURE LIMIT : -40℃...100℃
- STORAGE TEMPERATURE LIMIT : -40℃...85℃
- FUSE PERFORMANCE : PERFORMANCE OF THIS PART CONFORMS TO PES-A52-079.
- FUSE FIXING METHOD : USE TWO M10 BOLTS.
- COMPLY WITH ENVIRONMENTAL RESTRICTION AND PROHIBITION WHICH PRESCRIBED UNDER "PES-02-04".

注記

- 左図は600Aヒューズを示す。
- 表示はレーザーマーカで印字する事。表示は図面の向きで印字する事。
- "B"部の数字は社内品番を示す。
- "C"部には当社製造LOT NO.を表示する事。
- "D"部にはデータマトリクスコードを表示する事。データマトリクスコードはECC200・ISO/IEC16022に準じて印字する事。

NOTE

- THE DRAWING ABOVE SHOWS THE 600A FUSE.
- THE CAUTION IS MARKED BY LASER MARKER, AND THE DIRECTION OF THE CAUTION REFER TO THE DRAWING.
- "B" PORTION SHOWS PEC'S PART NUMBER.
- "C" PORTION SHOWS A PRODUCT LOT NUMBER.
- "D" PORTION SHOWS A DATA MATRIX CODE(DMC). THE DMC IS MARKED ACCORDING TO ECC200・ISO/IEC16022.

6	-	ADHESIVE	-	EPOXY RESIN	-	-
5	-	ARC-EXTINGUISHING SAND	-	SILICA	-	-
4	-	CASE B	1	UNSATURATED POLYESTER	-	-
3	-	CASE A	1	UNSATURATED POLYESTER	-	-
2	-	RING	2	COPPER	-	-
1	-	ELEMENT	1	COPPER	-	Tin PLATING
NO.	PART NO.	PART NAME	Q'TY	MATERIAL	SIZE	REMARKS

APPROVED	<i>H. Shibata</i>	DIMENSION TOLERANCE	ANGULAR TOLERANCE	FINISH
CHECKED	<i>J.L. Shimizu</i>	±0.2	-	-
DESIGNED	<i>Shuya Kataoka</i>	RUST PREVENTION	MATERIAL	
DRAWN	<i>Shuya Kataoka</i>	-	SEE TABLE	

SCALE	UNIT	DIAGRAM METHOD	PART NAME
1:1	mm	THIRD ANGLE PROJECTION	EVFP-38×64 ***A
DRAWING DATE	DRAWING NAME	3D CAD DATA	PART NO.
03/JUL/2020	G2970-0-4	-	SEE TABLE

Pacific Engineering Corporation

SHEET	SIZE
1 / 2	A3

△ 包装仕様 PACKAGING SPECIFICATION

NO.	DATE	REVISION RECORDS	REVISED	REVISION NO.
-	-	REFER TO (1/2)	-	-
-	-	-	-	-
-	-	-	-	-

包装内容 PACKAGING INFORMATION		内装 INNER PACKAGING	外装 OUTER PACKAGING
	包装材料 MATERIAL	包装用トレイ TRAY PEシート PE SHEET(0.02×1000×1300)	V-8 段ボ-ル CARDBOARD BOX V-8 (355×270×185)
	品番シール SEAL OF PART No.	-	現品票 ID TAG
	表示 MARKING	表示なし NOT APPLICABLE	外装に現品票の貼り付あり ID TAG ATTACHED ON OUTER PACKAGE
	収容数 CAPACITY	8 PCS.	32 PCS.
包装方法 METHOD	<p>1.トレ-にヒ-ズを詰める。 2.段ボ-ル箱に PEシートを敷く。 3.ヒ-ズを詰めたトレ-4段積みで詰める。 4.PEシートで包んでからテープで封をする。 5.段ボ-ル側面に現品票を貼る。</p> <p>1.PUT THE FUSES IN THE TRAY. 2.SPREAD A PE SHEET IN THE CARDBOARD BOX. 3.STACK STUFFED TRAY WHICH FILLED WITH FUSES IN 4LAYERS INTO THE BOX. 4.WRAP THEM BY THE PE SHEET. SEAL THE BOX BY THE TAPE. 5.PUT ID TAG ON THE SIDE OF CARDBOARD BOX.</p>		
保管条件 SAFEKEEPING CONDITION	<p>水ぬれ無き事。 温度：-40℃~85℃、湿度：RH80%以下 NO WET. TEMPERATURE: -40℃ TO 85℃、HUMIDITY : RH80% MAX.</p>		

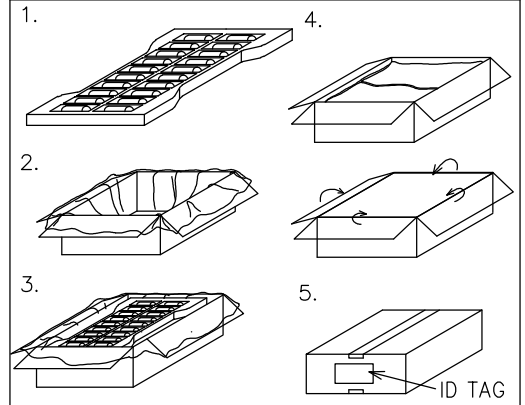

NO.	PART NO.	PART NAME	Q'TY	MATERIAL	SIZE	REMARKS
APPROVED	<i>N. Shibata</i>	DIMENSION TOLERANCE	ANGULAR TOLERANCE	FINISH		
CHECKED	<i>H. Shimizu</i>	-	-	-		
DESIGNED	<i>Shuya Kataoka</i>	RUST PREVENTION	MATERIAL			
DRAWN	<i>Shuya Kataoka</i>	-	-			
SCALE	UNIT	DIAGRAM METHOD	PART NAME			
1:1	mm	THIRD ANGLE PROJECTION	EVFP-38×64 ***A			
DRAWING DATE	DRAWING NAME	3D CAD DATA	PART NO.			
03/JUL/2020	G2970-0-4	-	SEE TABLE ON PAGE 1/2			
Pacific Engineering Corporation						
						SHEET
						2 / 2
						SIZE
						A3